

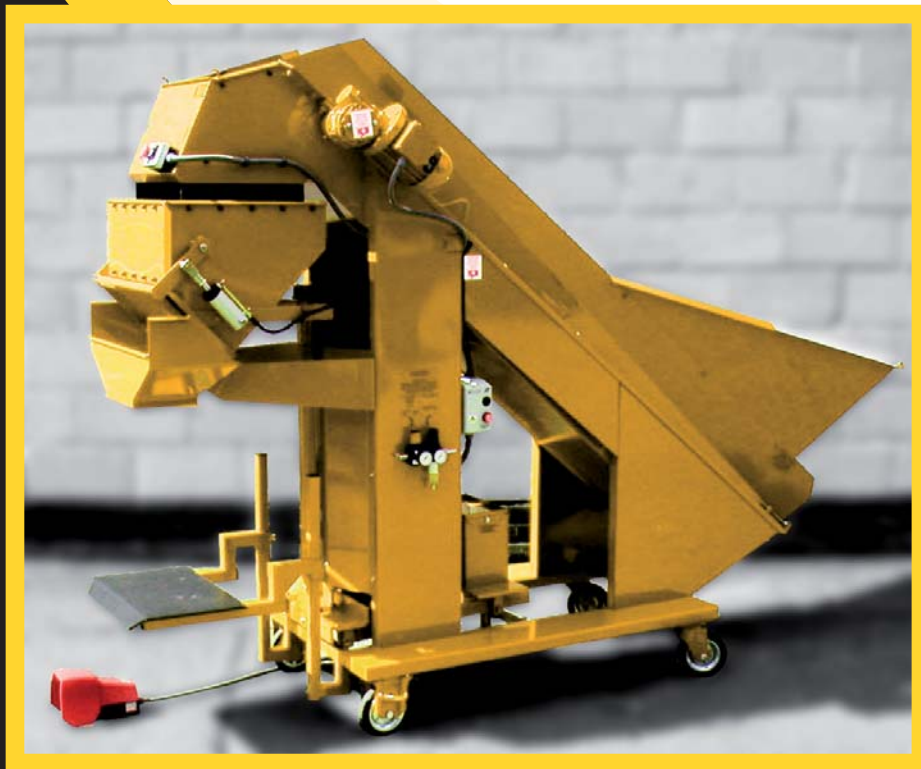

WALTHAMBURY®

POTATO WEIGHER



M300 NET WEIGHER

M300 NET WEIGHER

Developed from the successful M320 gross weighers, the M300 net weighers offer increased throughput with one man operation and more manageable control when filling polypropylene woven, hessian or jute sacks.

- Fills up to 300 bags per hour of potatoes, carrots, root crops or processed vegetables into paper, hessian or plastic bags.
- Pneumatic weigh hopper discharge gate with foot pedal control for ease of operation.
- Mechanical scale or electronic weighing system.
- Automatic refill when the weigh hopper is discharged to obtain maximum throughput.
- Contact parts rubber lined for complete produce protection.
- Discharge chute as standard.
- Twin belt design, main fill and top-up, for maximum efficiency.

Optional Extras

- Stainless steel, food quality construction.
- Dual weigh bins for accuracy at low weights.
- PLC and conveyor systems for automatic tray or cartion filling operations.
- Modifications to allow for use in various weight ranges between 5kg and 25kg
- Enlarged weigh hopper for 50kg weightments.
- Pnuematic bag clamp.
- Tray platform.

After Sales Service

Fast on site service by factory trained engineers coupled with extensive stocks of competitively priced spare parts guarantees maximum productivity and protects the customer's investment.

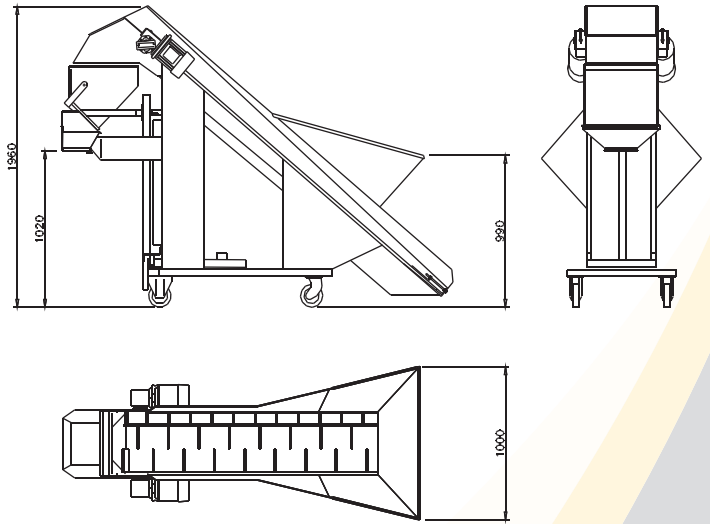

TECHNICAL SPECIFICATIONS

Throughput

Up to 300 bags per hour (depending on produce and bag size)

Weight Range

20kg to 25kg as standard (5kg to 50kg optional).

Air Requirements

A cool dry air supply, 5.5bar (5cfm/142 ltr/min @ 80psi)

Electrical Requirement

440VAC 3 phase or
240VAC single phase
Motors- 2 @ 370W



Walthambury

New Walthambury House,
Anglia Way, Braintree,
Essex, CM7 3RG, UK.
Tel: +44 (0)1376 322722
Fax: +44 (0)1376 323277
E-Mail: sales@morrays.com
www.walthambury.com